

**STANDARDS COMMITTEE FOR
HI-LOK® HI-TIGUE® PRODUCTS**
2800 SKYPARK DRIVE, TORRANCE, CALIFORNIA 90509

⑤ HI-SHEAR CORPORATION, U.S.A. (Patent Holder) U.S. Federal Code I.D. No. 73197
Division of Hi-Shear Industries Inc.
VOI-SHAN, Division of VSI Corp., U.S.A. (Licensee) U.S. Federal Code I.D. No. 92215
SPS TECHNOLOGIES, U.S.A. (Licensee) U.S. Federal Code I.D. No. 56878
LITTON FASTENING SYSTEMS, U.S.A. (Licensee) U.S. Federal Code I.D. No. 97928
Division of Litton Systems, Inc.

KAMAX-WERKE, Germany (Licensee)
Rudolph Kellerman GmbH & Co.
ST. CHAMOND-GRANAT, S.A. France (Licensee)
TOKYO SCREW COMPANY, Japan (Licensee)

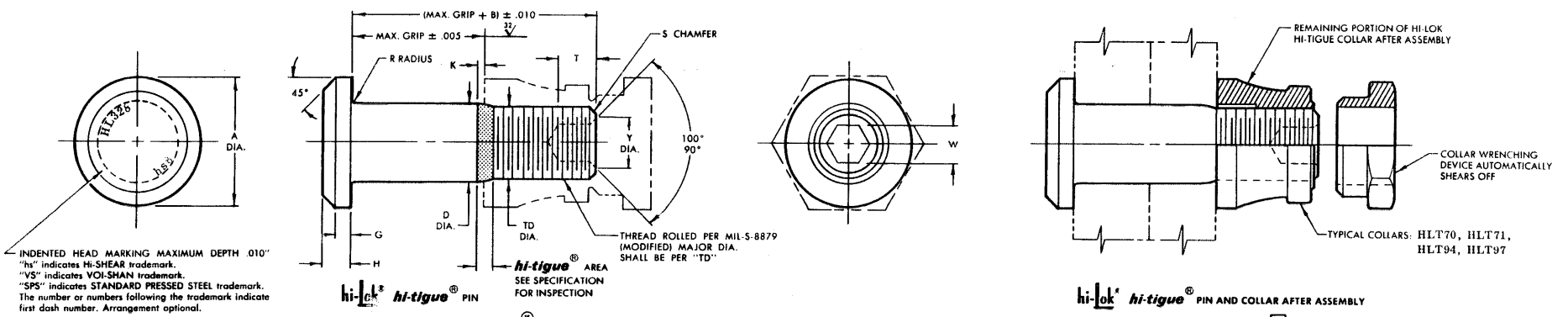

FIRST DASH NO.	NOM. DIA.	A DIA.	B REF.	D DIA.	TD DIA.	G REF.	H	K REF.	R RAD.	S CHAMFER REF.	THREAD	SOCKET			DOUBLE SHEAR POUNDS MINIMUM	TENSION POUNDS MINIMUM	MIN. GRIP LENGTH
												W HEX.	T DEPTH	Y DIA.			
-4	1/8	.250 .230	.294	.1375 .1365	.1335 .1310	.020	.042 .032	.010	.020 .010	1/32" x 45°	6-32 UNJC-3A Modified	.0645 .0635	.080 .065	.090 .075	2,840	1,350	-2
-5	5/32	.262 .242	.312	.1650 .1640	.1595 .1570	.020	.047 .037	.013	.025 .015	1/32" x 45°	8-32 UNJC-3A Modified	.0801 .0791	.135 .115	.104 .094	4,560	2,200	-2
-6	3/16	.315 .295	.325	.1895 .1885	.1840 .1810	.025	.055 .045	.016	.025 .015	1/32" x 45°	10-32 UNJF-3A Modified	.0806 .0791	.100 .080	.119 .104	6,100	2,900	-2
-8	1/4	.412 .387	.395	.2495 .2485	.2440 .2410	.030	.069 .059	.021	.025 .015	1/32" x 45°	1/4-28 UNJF-3A Modified	.0967 .0947	.110 .090	.142 .122	10,600	5,100	-2
-10	5/16	.505 .475	.500	.3120 .3110	.3060 .3020	.035	.078 .068	.026	.030 .020	3/64" x 45°	5/16-24 UNJF-3A Modified	.1295 .1270	.130 .110	.180 .160	16,600	7,100	-3
-12	3/8	.600 .565	.545	.3745 .3735	.3680 .3640	.040	.088 .078	.030	.030 .020	3/64" x 45°	3/8-21 UNJF-3A Modified	.1617 .1582	.160 .140	.217 .197	23,900	9,800	-4
-14	7/16	.676 .641	.635	.4370 .4360	.4310 .4260	.045	.105 .095	.035	.030 .020	3/64" x 45°	7/16-20 UNJF-3A Modified	.1930 .1895	.190 .170	.253 .233	32,500	14,000	-4
-16	1/2	.770 .735	.685	.4995 .4985	.4930 .4880	.050	.115 .103	.039	.030 .020	3/64" x 45°	1/2-20 UNJF-3A Modified	.2242 .2207	.220 .200	.289 .269	42,400	17,800	-5
-18	9/16	.864 .829	.770	.5615 .5605	.5550	.055	.127 .112	.039	.040 .025	1/16" x 45°	9/16-18 UNJF-3A Modified	.2555 .2520	.260 .240	.326 .306	53,700	21,500	

SEE COLLAR STANDARDS FOR COLLAR STRENGTHS. LOWER STRENGTH (PIN OR COLLAR) DETERMINES SYSTEM STRENGTH.

- GENERAL NOTES:
1. Concentricity: "A" to "D" diameter within .010 FTR.
 2. Dimensions to be met after plating.
 3. Surface texture per ANSI B46.1.
 4. Hole preparation per NAS618.
 5. Use HLT428 for oversize replacement.
 6. Minimum required for head and HI-Tigue feature. Standard HI-Lok pins available in shorter grips.

CODE: First dash number indicates nominal diameter in 1/32nds.
Second dash number indicates maximum grip in 1/16ths.
See "Finish" note for explanation of code letters.

HOW TO ORDER
EXAMPLES:

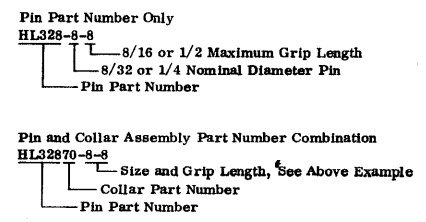

MATERIAL: Alloy steel per Spec. MIL-S-5000, MIL-S-5626, or MIL-S-6049.
HEAT TREAT: 108,000 psi shear minimum (180,000-200,000 psi tensile per Spec. MIL-H-6875).
FINISH: HL328-()-() = Cadmium plate per Spec. QQ-P-416, Type II, Class 2, and cetyl alcohol lube per Hi-Shear Spec. 305.
HL328TB-()-() = Cadmium plate per QQ-P-416, Type II, Class 2; Hi-Kote 2 solid film lube per Hi-Shear Spec. 292, and cetyl alcohol lube per Hi-Shear Spec. 305.
SPECIFICATION: HI-Lok HI-Tigue Product Specification 342.

U.S. patents 3,138,987; 3,390,906; 3,578,367, and foreign patents. "Hi-Lok," "HL," "Hi-Tigue," and "HLT" are Registered Trademarks of Hi-Shear Corporation.

DRAWN	DATE	<p>PROTRUDING SHEAR HEAD ALLOY STEEL 1/16" GRIP VARIATION INTERFERENCE APPLICATION</p>
SHRODE	1-24-68	
APPROVED	DATE	
J. MILLER	1-26-68	
REVISION	DATE	DRAWING NUMBER
(15)	D. P. S. 7-22-81	HL328

HL328