

**STANDARDS COMMITTEE  
FOR HI-LOK® PRODUCTS**  
2600 SKYPARK DRIVE, TORRANCE, CALIFORNIA 90509

HI-SHEAR CORPORATION (Patent Holder) — Federal Code Ident. No. 73197  
VOI-SHAN DIV., VSI CORP. (Licensee) — Federal Code Ident. No. 92215  
STANDARD PRESSED STEEL CO. (Licensee) — Federal Code Ident. No. 56878

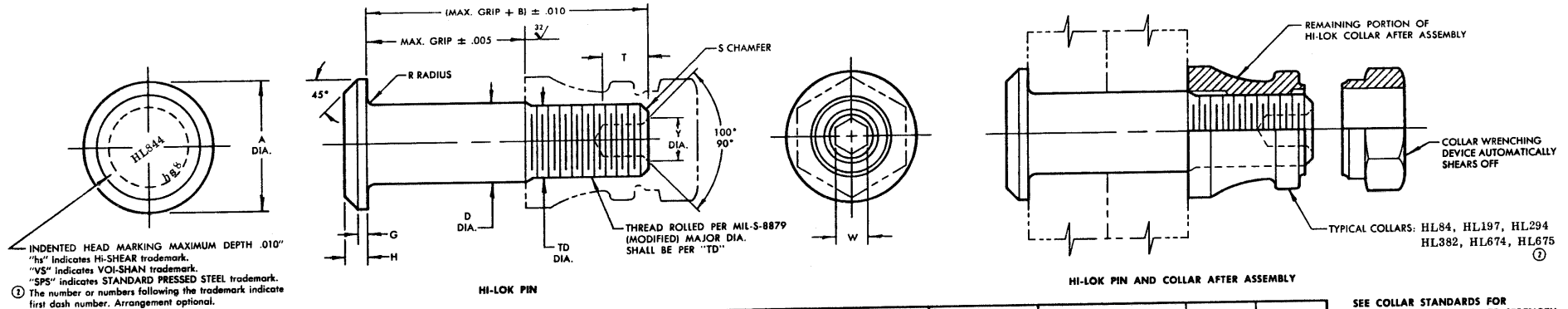

FIRST DASH NO.	NOM. DIA.	A DIA.	B REF.	D DIA. [5]		TD DIA.	G REF.	H	R RAD.	S CHAMFER REF.	THREAD	SOCKET			** DOUBLE SHEAR POUNDS MINIMUM	TENSION POUNDS MINIMUM
				WITHOUT SOLID FILM LUBE	WITH SOLID FILM LUBE							W HEX.	T DEPTH	Y DIA.		
-5	13/64			NOTE: Use HL744-6												
① -6	7/32	.315 .295	.325	.2182 .2177	.2182 .2172	.1940 .1810	.025	.055 .045	.025 .015	1/32" x 45°	10-32UNJF-3A Modified	.0906 .0791	.100 .080	.119 .104	9,400	3,000
② -8	9/32	.412 .387	.395	.2807 .2802	.2807 .2797	.2440 .2410	.030	.069 .059	.025 .015	1/32" x 45°	1/4-28UNJF-3A Modified	.0967 .0947	.110 .090	.142 .122	15,500	5,100
-10	11/32	.505 .475	.500	.3432 .3427	.3432 .3422	.3060 .3020	.035	.078 .068	.030 .020	3/64" x 45°	5/16-24UNJF-3A Modified	.1295 .1270	.130 .110	.180 .160	23,200	8,000
-12	13/32	.600 .565	.545	.4057 .4052	.4057 .4047	.3680 .3640	.040	.088 .078	.030 .020	3/64" x 45°	3/8-24UNJF-3A Modified	.1617 .1582	.160 .140	.217 .197	32,400	11,300
-14	15/32	.676 .641	.635	.4682 .4677	.4682 .4672	.4310 .4260	.045	.105 .093	.030 .020	3/64" x 45°	7/16-20UNJF-3A Modified	.1930 .1895	.190 .170	.253 .233	43,100	15,500
-16	17/32	.770 .735	.685	.5307 .5302	.5307 .5297	.4930 .4880	.050	.115 .103	.030 .020	3/64" x 45°	1/2-20UNJF-3A Modified	.2242 .2207	.220 .200	.289 .269	55,400	20,000
-18	19/32	.864 .829	.770	.5927 .5922	.5927 .5917	.5550 .5500	.055	.127 .112	.040 .025	1/16" x 45°	9/16-18UNJF-3A Modified	.2555 .2520	.260 .240	.326 .306	69,200	25,000
-20	21/32	.953 .918	.825	.6552 .6547	.6552 .6542	.6180 .6120	.060	.137 .122	.040 .025	1/16" x 45°	5/8-18UNJF-3A Modified	.2555 .2520	.260 .240	.326 .306	84,500	30,200
-24	25/32	1.108 1.066	1.050	.7802 .7797	.7802 .7792	.7430 .7370	.070	.151 .136	.045 .030	1/16" x 45°	3/4-16UNJF-3A Modified	.3185 .3150	.330 .300	.398 .378	120,000	40,200
-28	29/32	1.285 1.241	1.210	.9052 .9047	.9052 .9042	.8680 .8610	.090	.187 .172	.050 .035	5/64" x 45°	7/8-14UNJF-3A Modified	.3820 .3780	.400 .370	.471 .451	161,000	59,100
-32	1-1/32	1.468 1.424	1.390	1.0302 1.0297	1.0302 1.0292	.9930 .9860	.110	.218 .203	.060 .045	5/64" x 45°	1-12UNJF-3A Modified	.5100 .5040	.520 .490	.618 .598	209,000	80,000

SEE COLLAR STANDARDS FOR COLLAR STRENGTHS. LOWER STRENGTH (PIN OR COLLAR) DETERMINES SYSTEM STRENGTH.

- GENERAL NOTES:**
1. Concentricity: "A" to "D" diameter within .010 FIR.
  2. Dimensions to be met after finish.
  3. Surface texture per ANSI B46.1. ②
  4. Hole preparation per NAS618.
  5. Maximum "D" diameter may be increased by .0002 to allow for solid film application.

**MATERIAL:** PH13-8Mo stainless steel per Spec. AMS5629.

**HEAT TREAT:** 125,000 psi shear minimum.

**FINISH:** HL844-( )-( ) = Solid film lube per Spec. MIL-L-8937.  
HL844LL-( )-( ) = Passivate per HI-Shear Spec. 258 and cetyl alcohol lube per HI-Shear Spec. 305.

② HL844TB-( )-( ) = HI-Kote 2 solid film lube per HI-Shear Spec. 292 and cetyl alcohol lube per HI-Shear Spec. 305.

**SPECIFICATION:** HI-Lok Product Specification 342.

**CODE:** First dash number indicates nominal diameter in 1/32nds which HL844 oversize pin replaces.  
Second dash number indicates maximum grip in 1/16ths.  
See "Finish" note for explanation of code letters.

**HOW TO ORDER EXAMPLES:**

Pin Part Number Only

HL844-3-3

8/16 or 1/2 Maximum Grip Length

Replaces 8/32 or 1/4 Nominal Diameter Pin

Pin Part Number

Pin and Collar Assembly Part Number Combination

HL84484-8-3

8 Size and Grip Length, See Above Example

Collar Part Number

Pin Part Number

\*\* The Double Shear values shown are based on cross sectional area for nominal diameter pin.

U.S. patents 2,882,773; 2,927,491; 2,940,495; 3,027,789; 3,138,987; design patent 191,883; other U.S. and Foreign patents granted and pending; property of Hi-Shear Corporation. "Hi-Lok" and "HL" are Registered Trademarks of Hi-Shear Corporation.	
DRAWN VAN 11-19-71	DATE
APPROVED R 12-11-22-71	DATE
REVISION ② VAN 1-10-75	DATE
DRAWING NUMBER <b>HL844</b>	