

# STANDARDS COMMITTEE FOR HI-LOK® HI-TIGUE® PRODUCTS

2600 SKYPARK DRIVE, TORRANCE, CALIFORNIA 90509 U.S.A.

HI-SHEAR CORPORATION, U.S.A. (Patent Holder) CAGE No. 06725  
 A Subsidiary of GRI Industries, France  
 AIR INDUSTRIES CO., INC. (Licensee - U.S. & Canada) CAGE No. 06725  
 HUCK INTERNATIONAL, INC., Deutch Operation, U.S.A. (Licensee) CAGE No. 07928  
 SPS TECHNOLOGIES, U.S.A. (Licensee) CAGE No. 50878  
 FAIRCHILD Aerospace Fastener Division, U.S.A. (Licensee) CAGE No. 82218  
 WEST COAST AEROSPACE INC., U.S.A. (Licensee) CAGE No. 80618  
 (Pin & Steel Collars)

HI-SHEAR FASTENERS EUROPE, LTD., U.K. (Licensee) CAGE No. 0L808  
 A Subsidiary of GRI Industries, France  
 HUCK INTERNATIONAL GmbH & Co. Germany (Licensee - EEC Countries)  
 ST. CHAMOND GRANAT, S.A. France (Licensee - EEC Countries)  
 SIMMONDS, S.A. France (Licensee - EEC Countries - Collars)  
 TOKYO SCREW COMPANY, Japan (Licensee - Japan)

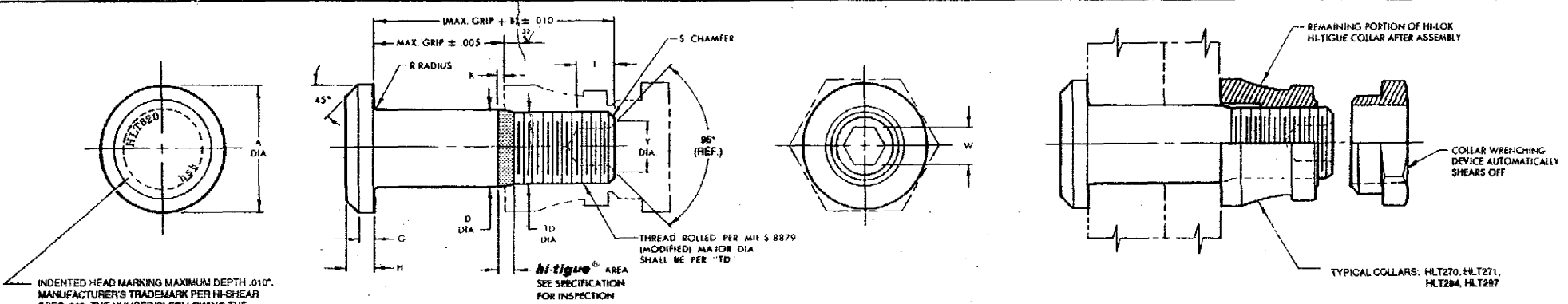

INDENTED HEAD MARKING MAXIMUM DEPTH .010".  
 MANUFACTURER'S TRADEMARK PER HI-SHEAR SPEC. 303. THE NUMBER(S) FOLLOWING THE TRADEMARK INDICATE FIRST DASH NUMBER. ARRANGEMENT OPTIONAL.

HI-LOK HI-TIGUE PIN

HI-LOK HI-TIGUE PIN AND COLLAR AFTER ASSEMBLY

FIRST DASH NO.	NOM. DIA.	A DIA.	B REF.	D DIA		TD DIA.	G REF.	H	K REF.	R RAD.	S CHAMFER REF.	THREAD	SOCKET			DOUBLE SHEAR POUNDS MINIMUM	TENSION POUNDS MINIMUM
				WITHOUT PLATING OR COATING	WITH PLATING OR COATING								W HEX.	T DEPTH	Y DIA.		
5																	
NOTE: USE HLT420-6(-)																	
6	13/64	.315 .295	.360	.2026 .2021	.2026 .2016	.1840 .1810	.025	.055 .045	.016	.025 .015	1/32" x 45°	10-32UNJF-3A Modified	.0806 .0791	.100 .080	.119 .104	8,100	3,000
8	17/64	.412 .387	.435	.2651 .2646	.2651 .2641	.2440 .2410	.030	.069 .059	.021	.025 .015	1/32" x 45°	1/4-28UNJF-3A Modified	.0967 .0947	.110 .090	.142 .122	13,800	5,100
10	21/64	.505 .475	.545	.3276 .3271	.3276 .3266	.3060 .3020	.035	.078 .068	.026	.030 .020	3/64" x 45°	5/16-24UNJF-3A Modified	.1295 .1270	.130 .110	.180 .180	21,100	8,000
12	25/64	.600 .565	.590	.3901 .3896	.3901 .3891	.3680 .3640	.040	.088 .078	.030	.030 .020	3/64" x 45°	3/8-24UNJF-3A Modified	.1617 .1582	.160 .140	.217 .197	30,000	11,300
14	29/64	.676 .641	.690	.4526 .4521	.4526 .4516	.4310 .4260	.045	.105 .093	.035	.030 .020	3/64" x 45°	7/16-20UNJF-3A Modified	.1930 .1895	.190 .170	.253 .233	40,300	15,500
16	33/64	.770 .735	.740	.5151 .5146	.5151 .5141	.4930 .4890	.050	.115 .103	.039	.030 .020	3/64" x 45°	1/2-20UNJF-3A Modified	.2242 .2207	.220 .200	.289 .269	52,500	20,000
18	37/64	.864 .829	.825	.5771 .5766	.5771 .5761	.5550 .5500	.055	.127 .112	.039	.040 .025	1/16" x 45°	9/16-18UNJF-3A Modified	.2555 .2520	.260 .240	.326 .306	65,600	25,000
20	41/64	.953 .918	.890	.6396 .6391	.6396 .6386	.6180 .6120	.060	.137 .122	.044	.040 .025	1/16" x 45°	5/8-18UNJF-3A Modified	.2555 .2520	.260 .240	.326 .306	80,600	30,200
24	49/64	1.108 1.066	1.115	.7646 .7641	.7646 .7636	.7430 .7370	.070	.151 .136	.044	.045 .030	1/16" x 45°	3/4-16UNJF-3A Modified	.3185 .3150	.330 .300	.398 .378	115,000	40,200

SEE COLLAR STANDARDS FOR COLLAR STRENGTHS. LOWER STRENGTH (PIN OR COLLAR) DETERMINES SYSTEM STRENGTH.

**GENERAL NOTES:**

- Concentricity: "A" to "D" diameter within .010 FIR.
- Dimensions to be met after finish.
- Surface texture per ANSI B46. 1.
- Hole preparation per NAS818.
- Use HLT714 for oversize replacement.

**MATERIAL:  
HEAT TREAT:  
FINISH:**

Nickel base alloy per AMS5662.  
 125,000 psi shear minimum (210,000 psi tensile minimum).  
 HLT620-(-)(-) = Passivate per Hi-Shear Spec. 258, and cetyl alcohol lube per Hi-Shear Spec. 305.  
 HLT620AP-(-)(-) = Hi-Kote 1 aluminum coating per Hi-Shear Spec. 294, and cetyl alcohol lube per Hi-Shear Spec. 305.  
 HLT620DL-(-)(-) = Solid film lube per AS5272, Type I, and cetyl alcohol lube per Hi-Shear Spec. 305.  
 HLT620FB-(-)(-) = Grit blast top of head, passivate per Hi-Shear Spec. 258, and cetyl alcohol lube per Hi-Shear Spec. 305.  
 HLT620FF-(-)(-) = Cadmium plate per QQ-P-416, Type II, Class 2, cetyl alcohol lube per Hi-Shear Spec. 305, and red identification on thread end.  
 HLT620FJ-(-)(-) = Hi-Kote 2 solid film lube per Hi-Shear Spec. 292, color red on thread end, and cetyl alcohol lube per Hi-Shear Spec. 305.  
 HLT620PB-(-)(-) = Cadmium plate per QQ-P-416, Type II, Class 2, and cetyl alcohol lube per Hi-Shear Spec. 305.  
 HLT620SK-(-)(-) = Grit blast top of head, passivate per Hi-Shear Spec. 258, with color brown on thread end, and cetyl alcohol lube per Hi-Shear Spec. 305.  
 HLT620SP-(-)(-) = Hi-Kote 2 solid film lube per Hi-Shear Spec. 292, with color brown on thread end, and cetyl alcohol lube per Hi-Shear Spec. 305.  
 HLT620TB-(-)(-) = Hi-Kote 2 solid film lube per Hi-Shear Spec. 292, and cetyl alcohol lube per Hi-Shear Spec. 305.

**SPECIFICATION:**

Hi-Lok Hi-Tigue Product Specification 342.

**CODE:**

First dash number indicates nominal diameter in 1/32nds of the pin which HLT620 oversize pin replaces. Second dash number indicates maximum grip in 1/16ths. See Finish note for explanation of code letters.

**HOW TO ORDER EXAMPLE:**

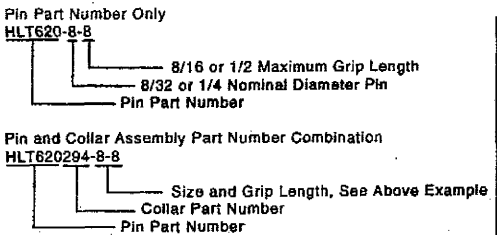

DRAWN DATE		TITLE	
S.Graphics	6-2-83	HI-LOK® HI-TIGUE® PIN PROTRUDING SHEAR HEAD NICKEL BASE ALLOY (INCONEL 718) 1/16" GRIP VARIATION, 1/64" OVERSIZE	
APPROVED DATE		DRAWING NUMBER	
R.Ting	6-6-83	HLT620	
REVISION DATE		DRAWING NUMBER	
9	J.Henderson 10-1-97	HLT620	

HLT620