

**STANDARDS COMMITTEE FOR
HI-LOK® HI-TIGUE® PRODUCTS**
2600 SKYPARK DRIVE, TORRANCE, CALIFORNIA 90509

① HI-SHEAR CORPORATION, U.S.A. (Patent Holder) U.S. Federal Code I.D. No. 73197
 Division of HI-Shear Industries Inc., U.S.A. (Licensee)
 AIRCRAFT FASTENERS (Forged Parts) LTD., U.K. (Licensee)
 Division of HI-Shear Industries Inc., U.S.A. (Licensee)
 VOI-SHAN, Division of VSI Corp., U.S.A. (Licensee) U.S. Federal Code I.D. No. 92215
 SPS TECHNOLOGIES, U.S.A. (Licensee) U.S. Federal Code I.D. No. 56878
 LITTON FASTENING SYSTEMS, U.S.A. (Licensee) U.S. Federal Code I.D. No. 97928
 Division of Litton Systems Inc., U.S.A. (Licensee)

ST. CHAMOND-GRANAT, S.A. France (Licensee—EEC Countries)
 KAMAX-WERKE, Germany (Licensee—EEC Countries)
 Rudolph Kellermann GmbH & Co. (Licensee—EEC Countries—Collars)
 SIMMONDS, S.A. France (Licensee—EEC Countries)
 TOKYO SCREW COMPANY, Japan (Licensee—Japan)
 WEST COAST AEROSPACE INC., U.S.A. (Licensee—Oversize Pins & Steel Collars)
 U.S. Federal Code I.D. No. 60516

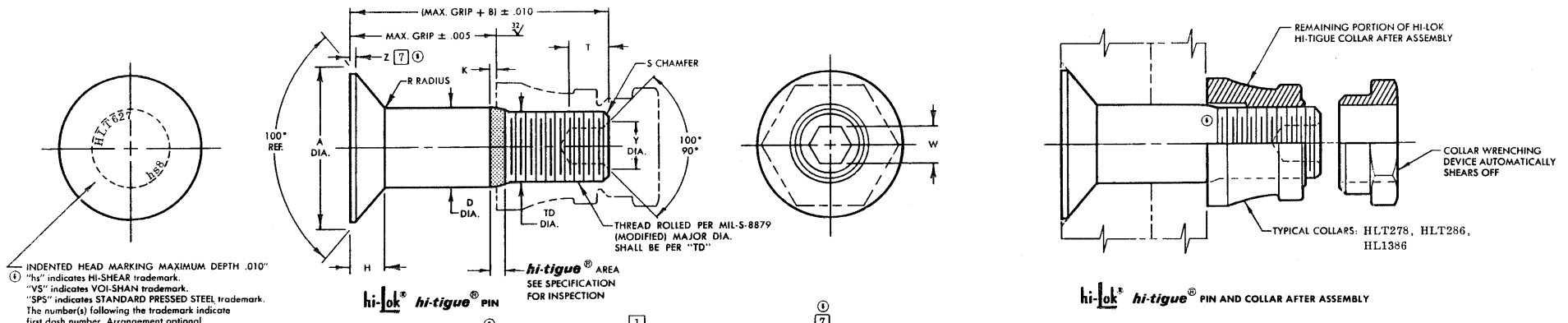

INDENTED HEAD MARKING MAXIMUM DEPTH .010"
 ① "hs" indicates HI-SHEAR trademark.
 "vs" indicates VOI-SHAN trademark.
 "SPS" indicates STANDARD PRESSED STEEL trademark.
 The number(s) following the trademark indicate first dash number. Arrangement optional.

FIRST DASH NO.	NOM. DIA.	A DIA.	B REF.	D DIA.	TD DIA.	F	H	K REF.	R RAD.	Z MAX.	S CHAMFER REF.	THREAD	SOCKET			DOUBLE SHEAR POUNDS MINIMUM	TENSION POUNDS MINIMUM
													W HEX.	T DEPTH	Y DIA.		
-5	3/16			NOTE: Use HL327-6													
-6	7/32	.3813 .3765	.360	.2182 .2172	.1840 .1810	.005	.0684 .0664	.022	.030 .020	.015	1/32" x 45°	10-32UNJF-3A Modified	.0806 .0791	.100 .080	.119 .104	7,100	2,750
-8	9/32	.5066 .5018	.435	.2807 .2797	.2440 .2410	.006	.0948 .0928	.027	.030 .020	.015	1/32" x 45°	1/4-28UNJF-3A Modified	.0967 .0947	.110 .090	.142 .122	11,800	5,820
-10	11/32	.6335 .6287	.545	.3432 .3422	.3060 .3020	.007	.1218 .1198	.032	.040 .030	.015	3/64" x 45°	5/16-24UNJF-3A Modified	.1295 .1270	.130 .110	.180 .160	17,600	9,200
-12	13/32	.7604 .7556	.590	.4057 .4047	.3680 .3640	.008	.1488 .1468	.036	.040 .030	.015	3/64" x 45°	3/8-24UNJF-3A Modified	.1617 .1582	.160 .140	.217 .197	24,600	14,000
-14	15/32	.8884 .8812	.690	.4682 .4672	.4310 .4260	.009	.1763 .1733	.035	.050 .040	.022	3/64" x 45°	7/16-20UNJF-3A Modified	.1930 .1895	.190 .170	.253 .233	32,700	18,900
-16	17/32	1.0139 1.0068	.740	.5307 .5297	.4930 .4880	.010	.2027 .1997	.045	.050 .040	.022	3/64" x 45°	1/2-20UNJF-3A Modified	.2242 .2207	.220 .200	.289 .269	42,000	25,500
-18	19/32	1.1408 1.1337	.825	.5927 .5917	.5550 .5500	.010	.2300 .2270	.041	.050 .040	.022	1/16" x 45°	9/16-18UNJF-3A Modified	.2555 .2520	.260 .240	.326 .306	52,400	32,400

SEE COLLAR STANDARDS FOR COLLAR STRENGTHS. LOWER STRENGTH (PIN OR COLLAR) DETERMINES SYSTEM STRENGTH.

- GENERAL NOTES:
- Head edge out of roundness shall not exceed "F."
 - Concentricity: Conical surface of head to "D" diameter within .005 FIR.
 - "H" is dimensioned from maximum "D" diameter.
 - Dimensions to be met after plating.
 - Surface texture per ANSI B46.1.
 - Hole preparation per NAS618.
 - ⑦ Curved or flat edge manufacturer's option.

CODE: First dash number indicates nominal diameter in 1/32nds which HLT627 oversized pin replaces.
 Second dash number indicates maximum grip in 1/16ths.
 See "Finish" note for explanation of code letters.

HOW TO ORDER EXAMPLES:

Pin Part Number Only
 HLT627-8-8
 — 8/16 or 1/2 Maximum Grip Length
 — Replaces 8/32 or 1/4 Nominal Diameter Pin
 — Pin Part Number

Pin and Collar Assembly Part Number Combination
 HLT627278-8-8
 — Size and Grip Length. See Above Example
 — Collar Part Number
 — Pin Part Number

MATERIAL: Alloy steel per Spec. MIL-S-5000, MIL-S-5626 or MIL-S-6049.
 HEAT TREAT: 160,000—180,000 psi tensile per Spec. MIL-H-6875.
 FINISH: HLT627-()-() = Cadmium plate per Spec. QQ-P-416, Type II, Class 2, and cetyl alcohol lube per HI-Shear Spec. 305.
 HLT627TB-()-() = Cadmium plate per QQ-P-416, Type II, Class 2, HI-Kote 2 solid film lube per HI-Shear Spec. 292, and cetyl alcohol lube per HI-Shear Spec. 305.
 SPECIFICATION: HI-Lok HI-Tigue Product Specification 342.

U.S. patents 3,390,906; 3,578,367; and foreign patents. "Hi-Lok," "HL," "Hi-Tigue," and "HLT" are Registered Trademarks of HI-Shear Corporation.	
DRAWN VAN 6-24-69	DATE
APPROVED [Signature]	DATE
REVISION ⑥	DATE D. P. S. 10-6-83
hi-lok hi-tigue PIN 100° FLUSH MS24694 TENSION HEAD ALLOY STEEL 1/16" GRIP VARIATION - 1/32" OVERSIZE DRAWING NUMBER HLT627	

HLT627