

**STANDARDS COMMITTEE
FOR HI-LOK® HI-TIGUE® PRODUCTS**
2600 SKYPARK DRIVE, TORRANCE, CALIFORNIA 90509 U.S.A.

HI-SHEAR CORPORATION, U.S.A. (Patent Holder) CAGE No. 73197
 Division of Hi-Shear Industries Inc., U.S.A.
 AIR INDUSTRIES CO., INC., U.S.A. (Licensee - U.S. & Canada) CAGE No. 00725
 HUCK INTERNATIONAL, INC., Deutsch Operation, U.S.A. (Licensee) CAGE No. 97928
 SPS TECHNOLOGIES, U.S.A. (Licensee) CAGE No. 98878
 FAIRCHILD Aerospace Fastener Division, U.S.A. (Licensee) CAGE No. 92218
 WEST COAST AEROSPACE INC., U.S.A. (Licensee) CAGE No. 80618
 (Pins & Steel Collars)

HI-SHEAR FASTENERS EUROPE, LTD., U.K. (Licensee) - CAGE No. 0L808
 Division of Hi-Shear Industries Inc., U.S.A.
 HUCK INTERNATIONAL GMBH & CO., Germany (Licensee - EEC Countries)
 SAINT CHAMOND GRANAT, S.A. France (Licensee - EEC Countries)
 SIMMONDS S.A., France (Licensee - EEC Countries-Collars)
 TOKYO SCREW COMPANY, Japan (Licensee - Japan)

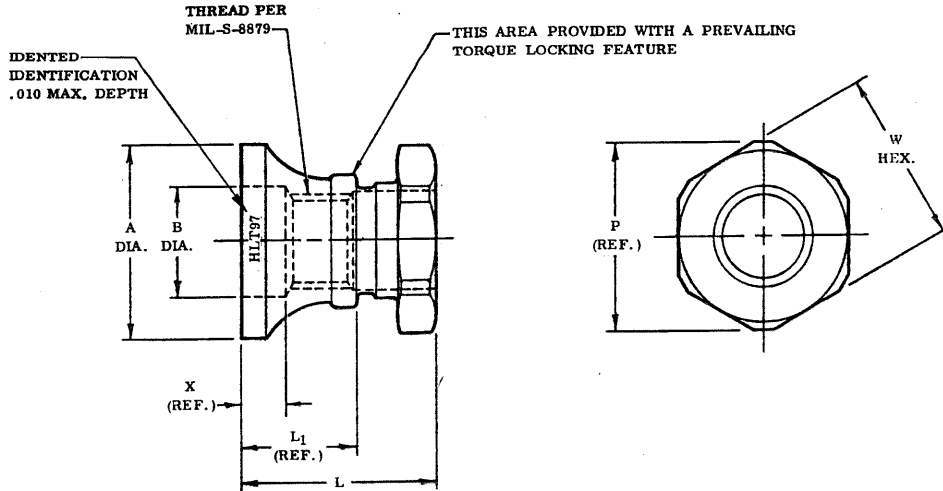

DASH NO.	PIN NOM. DIA.	THREAD	A DIA.	B DIA.	L LENGTH	L ₁ (REF.)	P (REF.)	W HEX.	X (REF.)	UTS LBS. MIN.	TORQUE-OFF INCH - LB.
5	5/32	8-32UNJC-3B	.287	.179	.447	.265	.344	.314	.118	1,940	25
			.283	.175	.427						15
			.307	.205	.457						35
6	3/16	10-32UNJF-3B	.303	.201	.437	.275	.344	.314	.118	2,500	25
			.412	.265	.552						80
8	1/4	1/4-28UNJF-3B	.408	.261	.532	.340	.484	.425	.127	4,300	60
10	5/16	5/16-24UNJF-3B	.518	.330	.672	.430	.624	.565	.139	6,300	160
			.512	.324	.652						130
12	3/8	3/8-24UNJF-3B	.620	.393	.744	.475	.715	.628	.139	8,700	240
			.614	.387	.724						200
14	7/16	7/16-20UNJF-3B	.733	.456	.862	.560	.840	.753	.157	12,100	330
			.727	.450	.842						270
16	1/2	1/2-20UNJF-3B	.848	.519	.942	.610	.970	.878	.157	15,300	430
			.842	.513	.922						370
18	9/16	9/16-18UNJF-3B	.915	.582	1.029	.670	1.045	.941	.171	20,500	575
			.905	.576	1.009						500
20	5/8	5/8-18UNJF-3B	.995	.650	1.123	.735	1.120	1.003	.171	25,700	700
			.985	.644	1.103						625
24	3/4	3/4-16UNJF-3B	1.120	.776	1.371	.940	1.240	1.128	.188	37,300	1000
			1.110	.770	1.351						900
28	7/8	7/8-14UNJF-3B	1.345	.902	1.571	1.060	1.520	1.380	.205	50,900	1325
			1.335	.896	1.551						1200
32	1	1-12UNJF-3B	1.490	1.030	1.836	1.225	1.650	1.504	.229	67,000	1600
			1.480	1.024	1.816						1450

- NOTES:**
- Go thread gage penetration shall be 3/4 of one revolution minimum.
 - Dimensions apply after finish.
 - Use HLT297 for oversize replacement.
 - For use on standard diameter Hi-Tigue pins.

MATERIAL: Collar - A-286 high temperature alloy per AMS5731, AMS5734, or AMS5736.

FINISH:

- HLT97-() = Silver plate per AMS2410 and cetyl alcohol lube per Hi-Shear Spec. 305.
- HLT97DU-() = Solid film lube per MIL-L-46010, Type I.
- HLT97PB-() = Cadmium plate per QQ-P-416, Type II, Class 2, and cetyl alcohol lube per Hi-Shear Spec. 305.
- HLT97TB-() = Hi-Kote 2 solid film lube per Hi-Shear Spec. 292 and cetyl alcohol lube per Hi-Shear Spec. 305.

SPECIFICATION: Hi-Lok Hi-Tigue Product Specification 345.

CODE: Dash number indicates nominal thread size in 1/32nds. See Finish note for explanation of code letters.

EXAMPLE: HLT97TB-8 = 1/4-28 Hi-Tigue Collar, finish is Hi-Kote 2 and cetyl alcohol.

"Hi-Lok", "HL", "Hi-Tigue, and "HLT" are internationally registered trademarks of Hi-Shear Corporation.

			TITLE	DRAWING NUMBER
DATE	BY		HI-LOK® HI-TIGUE® COLLAR A-286 HIGH TEMPERATURE ALLOY 1/16" GRIP VARIATION SHEAR APPLICATION	HLT97
DRAWN	5-21-69	Van		
APPROVED	6-5-69	V. Miller		
REVISION	5-25-95	J.F. Obispo		