

INDENTED HEAD MARKING MAX. DEPTH .010. IDENTIFY PART WITH NO. 200, MANUFACTURER'S TRADEMARK "hs", AND FIRST DASH NO. LOCATION OPTIONAL.

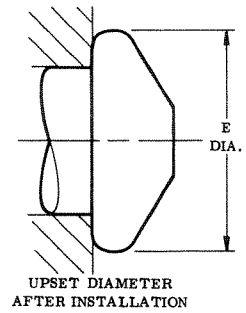
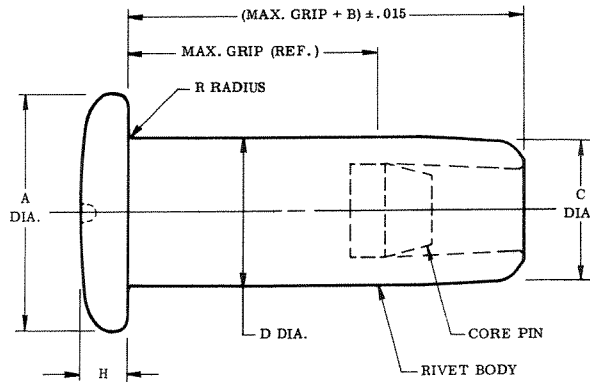
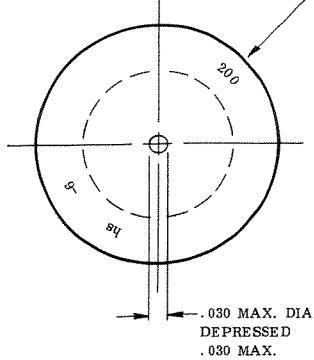

TABLE I

| FIRST DASH NO. | NOM. DIA. | A | B REF. | C REF. | D WITHOUT PLATING OR WITH SOLID FILM LUBE | D WITH PLATING | E | H | R RAD. REF. | DOUBLE SHEAR POUNDS MIN. |
|----------------|-----------|--------------|--------|--------|-------------------------------------------|----------------|--------------|--------------|-------------|--------------------------|
| -5 | 5/32 | .262 .242 | .143 | .151 | .1635 .1630 | .1635 .1625 | .237 .204 | .056 .037 | .025 | 4,010 |
| -6 | 3/16 | .315 .295 | .146 | .177 | .1895 .1890 | .1895 .1885 | .275 .236 | .064 .045 | .025 | 5,380 |
| -8 | 1/4 | .412 .387 | .216 | .237 | .2495 .2490 | .2495 .2485 | .362 .311 | .078 .059 | .035 | 9,300 |
| -10 | 5/16 | .505 .475 | .281 | .299 | .3120 .3115 | .3120 .3110 | .452 .389 | .090 .068 | .030 | 14,600 |
| -12 | 3/8 | .600 .565 | .347 | .362 | .3745 .3740 | .3745 .3735 | .543 .468 | .100 .078 | .030 | 21,000 |

TABLE II
GRIP RANGE AND AVAILABILITY

| GRIP RANGE SECOND DASH NUMBER | -5 DIA. | GRIP RANGE | | | |
|----------------------------------|--------------|--------------|----------------|-------------------------|-------------------------|
| | | -6 DIA. | -8 DIA. | -10 DIA. | -12 DIA. |
| -2 | .125 .094 | | | | |
| -2.5 | .156 .125 | | | | |
| -3 | .188 .156 | .188 .125 | .188 .125 | * * | * * |
| -3.5 | .219 .188 | .250 .188 | .250 .188 | .250 .188 | .250 .188 |
| -4 | .250 .219 | .312 .250 | .312 .250 | .312 .250 | .312 .250 |
| -4.5 | .281 .250 | .375 .312 | .375 .312 | .375 .312 | .375 .312 |
| -5 | .312 .281 | .438 .375 | .438 .375 | .438 .375 | .438 .375 |
| -5.5 | .344 .312 | .500 .438 | .500 .438 | .500 .438 | .500 .438 |
| -6 | .375 .344 | .562 .500 | .562 .500 | .562 .500 | .562 .500 |
| -6.5 | .406 .375 | .625 .562 | .625 .562 | .625 .562 | .625 .562 |
| -7 | .438 .406 | .688 .625 | .688 .625 | .688 .625 | .688 .625 |
| -7.5 | .469 .438 | .750 .688 | .750 .688 | .750 .688 | .750 .688 |
| -8 | .500 .469 | .812 .750 | .812 .750 | .812 .750 | .812 .750 |
| -8.5 | .531 .500 | .875 .812 | .875 .812 | .875 .812 | .875 .812 |
| -9 | .562 .531 | .938 .875 | .938 .875 | .938 .875 | .938 .875 |
| Longer Grip Lengths | | | | 1.000 .938 | 1.000 .938 |
| | | | | 1.062 1.000 | 1.062 1.000 |
| | | | | 1.125 1.062 | 1.125 1.062 |
| | | | | 1.188 1.125 1.188 | 1.188 1.125 1.188 |
| -20 | | | 1.250 1.188 | 1.250 1.188 | |
| -21 | | | 1.312 1.250 | 1.312 1.250 | |

- NOTES: 1. Concentricity: "A" diameter to "D" diameter within .005 FIR.
2. Surface Texture: 125√ maximum per ANSI B46.1.
3. See Table II for grip length availability.
4. Dimensions to be met before finish.

MATERIAL: A-286 CRES per AMS5731.

SHEAR STRENGTH: 95,000 psi minimum.

- FINISH: HSR200(-)(-) = Passivate per QQ-P-35 and cetyl alcohol lube per Hi-Shear Spec. 305.
HSR200AP(-)(-) = Hi-Kote 1 aluminum coating per Hi-Shear Spec. 294, and cetyl alcohol lube per Hi-Shear Spec. 305.
HSR200DK(-)(-) = Kalgard FA, cured for vacuum compatibility.
HSR200PN(-)(-) = Cadmium plate per QQ-P-416, Type II, Class 2.
HSR200PY(-)(-) = Passivate per QQ-P-35.
HSR200TB(-)(-) = Hi-Kote 2 solid film lube per Hi-Shear Spec. 292, and cetyl alcohol lube per Hi-Shear Spec. 305.

SPECIFICATION: Hi-Set Rivet Specification 332.

CODE: First dash number indicates nominal diameter in 1/32nds.
Second dash number indicates maximum grip length in 1/16ths. [3]

HOW TO ORDER
EXAMPLES:

(For -6 thru -12) HSR200-6-7
└── 7/16 Maximum Grip Length [3]
└── 6/32 or 3/16 Nominal Diameter
└── Rivet Part Number

(For -5 Only) HSR200-5-7
└── 7/16 Maximum Grip Length [3]
└── 5/32 Nominal Diameter
└── Rivet Part Number

HSR200-5-6.5
└── 6.5/16 or 13/32 Maximum Grip Length [3]
└── 5/32 Nominal Diameter
└── Rivet Part Number

* Parts not available.
Shaded portions of table are available, subject to special pricing and delivery.

U.S. Patents 4,223, 433 and 4,355, 531.
"Hi-Set" is a registered trademark of Hi-Shear Corporation.

| BY | | DATE | TITLE | DRAWING NUMBER |
|----------|---------------|-----------|--------------------------------------------------------------------------|----------------|
| DRAWN | <i>Shrade</i> | 8-23-74 | HI-SET® RIVET PROTRUDING CROWN SHEAR HEAD A-286 CRES, 95 KSI SHEAR | HSR200 |
| APPROVED | <i>Chant</i> | 8-26-74 | | |
| REV. | 3-11-93 | T.Craigne | | |