

hi-shear
CORPORATION

2600 Skypark Drive
Torrance, California 90509 U.S.A.
Telephone (310) 326-8110
FAX (310) 784-4144

CAGE = Commercial And Government Entity

HI-SHEAR CORPORATION, U.S.A. (Patent Holder) CAGE No. 73197
Division of Hi-Shear Industries, Inc., U.S.A.
AIR INDUSTRIES CO., INC. (Licensee - U.S. & Canada) CAGE No. 06725
SPS TECHNOLOGIES, U.S.A. (Licensee) CAGE No. 56878
HI-SHEAR FASTENERS EUROPE LTD., U.K. (Licensee) CAGE No. 0LB68
Division of Hi-Shear Industries, Inc., U.S.A.

HUCK INTERNATIONAL GmbH & Co. Germany (Licensee-EEC Countries)
SIMMONDS S.A. France (Licensee-EEC Countries-Collars)
St-CHAMOND GRANAT S.A. France (Licensee-EEC Countries)
TOKYO SCREW COMPANY, Japan (Licensee-Japan)
941103

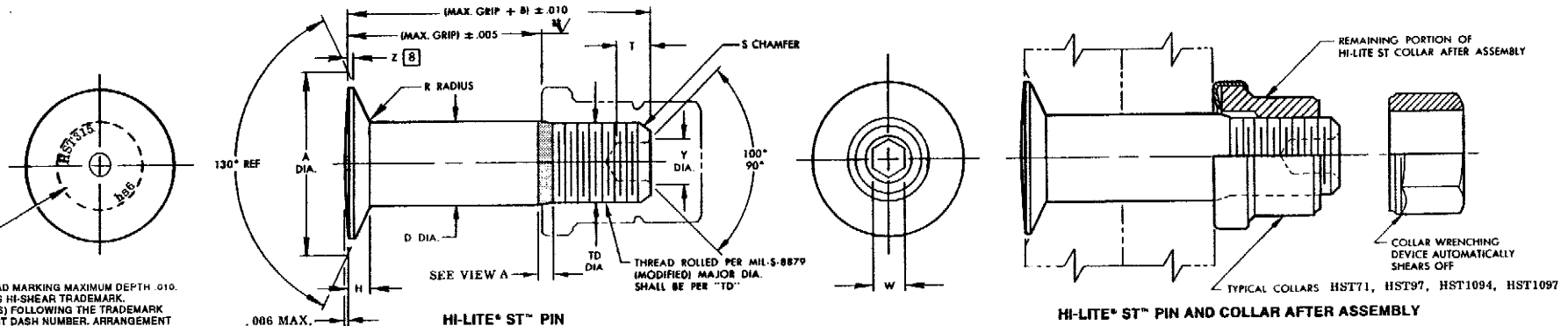

INDENTED HEAD MARKING MAXIMUM DEPTH .010.
"h" INDICATES HI-SHEAR TRADEMARK.
THE NUMBER(S) FOLLOWING THE TRADEMARK
INDICATE FIRST DASH NUMBER, ARRANGEMENT
OPTIONAL INDENTED CIRCLE .006 MAXIMUM DEPTH
CONCENTRIC TO "D" DIAMETER WITHIN .010 FIM. ①

FIRST DASH NO.	NOM. DIA.	A DIA.	B REF.	D DIA AFTER FINISH	TD DIA.	F REF.	H REF.	R RAD.	Z MAX.	S CHAMFER REF.	THREAD	SOCKET			DOUBLE SHEAR POUNDS MINIMUM	TENSION POUNDS MINIMUM
												W HEX.	T DEPTH	Y DIA.		
5	5/32	.3393 .3308	.280	.1635 .1625	.1595 .1570	.004	.0410 .0390	.025 .015	.012	1/32" x 37°	8-32UNJC-3A Modified	.0801 .0791	.100 .080	.104 .094	4,010	1,650
6	3/16	.3911 .3825	.290	.1895 .1885	.1840 .1810	.005	.0470 .0450	.030 .020	.015	1/32" x 37°	10-32UNJF-3A Modified	.0806 .0791	.100 .080	.119 .104	5,380	2,000
8	1/4	.5111 .5026	.320	.2495 .2485	.2440 .2410	.006	.0610 .0590	.030 .020	.015	1/32" x 37°	1/4-28UNJF-3A Modified	.0967 .0947	.110 .090	.142 .122	9,300	3,700
10	5/16	.6037 .5951	.380	.3120 .3110	.3060 .3020	.007	.0680 .0660	.040 .030	.015	3/64" x 37°	5/16-24UNJF-3A Modified	.1295 .1270	.130 .110	.180 .160	14,600	5,000
12	3/8	.7090 .7005	.420	.3745 .3735	.3680 .3640	.008	.0780 .0760	.040 .030	.015	3/64" x 37°	3/8-24UNJF-3A Modified	.1617 .1582	.160 .140	.217 .197	21,000	7,200
14	7/16	.8526 .8419	.485	.4370 .4360	.4310 .4260	.009	.0969 .0944	.050 .040	.020	3/64" x 37°	7/16-20UNJF-3A Modified	.1930 .1895	.190 .170	.253 .233	23,600	10,000

SEE COLLAR STANDARDS FOR COLLAR STRENGTHS. LOWER STRENGTH (PIN OR COLLAR) DETERMINES SYSTEM STRENGTH.

- GENERAL NOTES:
- Head edge out of roundness shall not exceed "F."
 - Concentricity: Conical surface of head to "D" diameter within .005 FIR.
 - "H" is dimensioned from maximum "D" diameter.
 - Dimensions to be met after finish.
 - Surface texture per ANSI B46. 1.
 - Hole preparation per NAS618.
 - Curved or flat edge manufacturer's option.
 - Use HST415 for oversize replacement.

CODE: First dash number indicates nominal diameter in 1/32nds.
Second dash number indicates maximum grip in 1/16ths.
See finish notes for explanation of finish code letters.

HOW TO ORDER
EXAMPLES:

Pin Part Number Only
HST315AG-8-BWD
— Bell Special
— 8/16 or 1/2 Maximum Grip Length
— 8/32 or 1/4 Nominal Diameter Pin
— Pin Part Number

Pin and Collar Assembly Part Number Combination
HST315AG71-8-BWD
— Bell Special
— Size and Grip Length, See Above Example
— Collar Part Number
— Pin Part Number

THIS AREA OF SPECIAL CONFIGURATION AND COLD WORKING TO MEET PHYSICAL REQUIREMENTS



VIEW A
HI-LITE THREAD TRANSITION AREA.
SEE SPECIFICATION FOR INSPECTION.

MATERIAL: 6Al-4V titanium alloy per AMS4928 or AMS4967.

HEAT TREAT: 95,000 psi shear minimum.

FINISH: HST315AG-()-()WD = Hi-Kote 1 aluminum coating per Hi-Shear Spec. 294, with color orange on thread end, and cetyl alcohol tube per Hi-Shear Spec. 305.

SPECIFICATION: Hi-Lite Product Specification 380.

U.S. Patents 4,326,825; 4,485,510 and 4,957,401.
Other U.S. and foreign patents pending.
"Hi-Lite" is a registered trademark and "Hi-Lite ST" is a trademark of Hi-Shear Corporation.

DRAWN DATE		TITLE
J.F.Obispo	8-20-96	HI-LITE® ST™ PIN 130° FLUSH CROWN SHEAR HEAD TITANIUM 1/16" GRIP VARIATION
APPROVED DATE		DRAWING NUMBER
MC	8-21-96	HST315WD
REVISION DATE		
①	JFO 9-12-96	