

HI-SHEAR CORPORATION, U.S.A. (Patent Holder) CAGE Code 73197	LISI AEROSPACE FRANCE (Licensee) CAGE Code F0188
a Lisi Aerospace Company	a Lisi Aerospace Company
AIR INDUSTRIES CO., INC., U.S.A. (Licensee - U.S.A & Canada) CAGE Code 06725	BLANC AERO INDUSTRIES UK LIMITED (Licensee) CAGE Code U6300
a Lisi Aerospace Company	a Lisi Aerospace Company
SPS TECHNOLOGIES, U.S.A. (Licensee) CAGE Code 56878	FT BESTAS, Izmer (Licensee) CAGE Code T0802
a Lisi Aerospace Company	a Lisi Aerospace Company
MINBEA CO. LTD. Japan (Licensee-Japan) CAGE Code SB962	LISI AEROSPACE CANADA (Licensee) CAGE Code L4528
	a Lisi Aerospace Company

INDENTED HEAD MARKING MAXIMUM DEPTH .010".  
"hs" INDICATES HI-SHEAR TRADEMARK.  
THE NUMBER(S) FOLLOWING THE TRADEMARK  
INDICATES FIRST DASH NUMBER.  
ARRANGEMENT OPTIONAL.

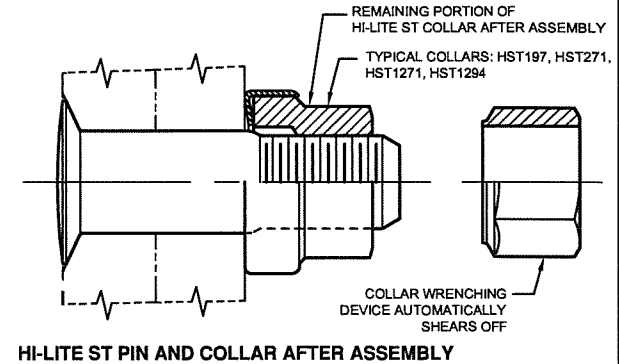
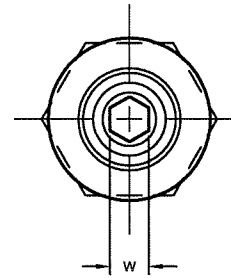
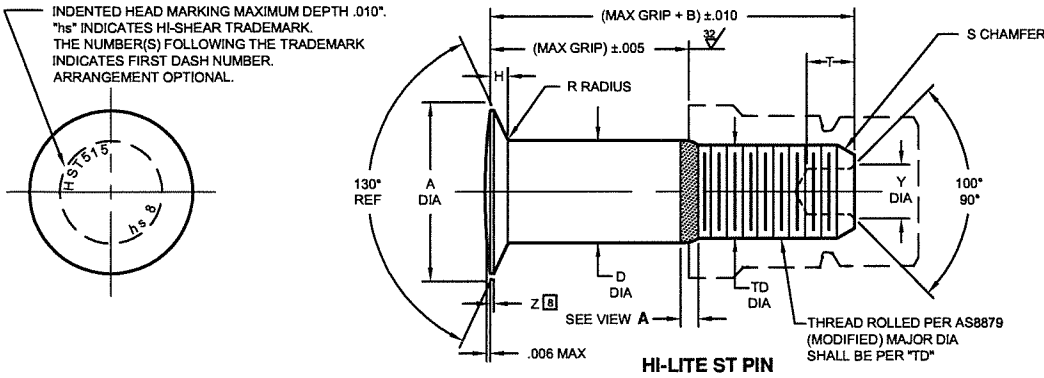

FIRST DASH NO.	PIN NOM DIA	A DIA	B REF	D DIA		TD DIA	F REF	H	R RAD	Z MAX	S CHAMFER REF	THREAD	SOCKET			DOUBLE SHEAR POUNDS MINIMUM	TENSION POUNDS MINIMUM
				WITHOUT COATING OR SOLID FILM	WITH COATING OR SOLID FILM								W HEX	T DEPTH	Y DIA		
NOTE: USE HST415-6(-)																	
6	7/32	.4198 .4112	.300	.2182 .2177	.2182 .2172	.1840 .1810	.005	.0470 .0450	.030 .020	.015	1/32" x 37°	10-32UNJF-3A Modified	.0806 .0791	.100 .080	.119 .104	7,100	2,000
8	9/32	.5423 .5337	.330	.2807 .2802	.2807 .2797	.2440 .2410	.006	.0610 .0590	.030 .020	.015	1/32" x 37°	1/4-28UNJF-3A Modified	.0967 .0947	.110 .090	.142 .122	11,800	3,700
10	11/32	.6349 .6263	.390	.3432 .3427	.3432 .3422	.3060 .3020	.007	.0680 .0660	.040 .030	.015	3/64" x 37°	5/16-24UNJF-3A Modified	.1295 .1270	.130 .110	.180 .160	17,600	5,000
12	13/32	.7402 .7316	.430	.4057 .4052	.4057 .4047	.3680 .3640	.008	.0780 .0760	.040 .030	.015	3/64" x 37°	3/8-24UNJF-3A Modified	.1617 .1582	.160 .140	.217 .197	24,600	7,200
14	15/32	.8838 .8731	.495	.4682 .4677	.4682 .4672	.4310 .4260	.009	.0969 .0944	.050 .040	.015	3/64" x 37°	7/16-20UNJF-3A Modified	.1930 .1895	.190 .170	.253 .233	32,700	10,000

SEE COLLAR STANDARDS FOR COLLAR STRENGTHS. LOWER STRENGTH (PIN OR COLLAR) DETERMINES SYSTEM STRENGTH.

**GENERAL NOTES:**

- Head edge out of roundness shall not exceed "F".
- Concentricity: Conical surface of head to "D" diameter within .005 FIM.
- "H" is dimensioned from maximum "D" diameter.
- Dimensions to be met after finish.
- Surface texture per ANSI B46.1.
- Hole preparation per NAS618.
- Maximum "D" diameter may be increased by .0002 to allow for solid film or aluminum coating application.
- Curved or flat edge manufacturer's option.

**MATERIAL:**

6AL-4V titanium alloy per AMS4928 or AMS4967.

**HEAT TREAT:**

95,000 psi shear minimum.

**FINISH:**

- HST515(-)(-) = Cetyl alcohol lube per Hi-Shear Spec. 305.
- HST515AG(-)(-) = Hi-Kote 1 aluminum coating per Hi-Shear Spec. 294, with color orange on thread end, and cetyl alcohol lube per Hi-Shear Spec. 305.
- HST515AP(-)(-) = Hi-Kote 1 aluminum coating per Hi-Shear Spec. 294, and cetyl alcohol lube per Hi-Shear Spec. 305.
- HST515BJ(-)(-) = I.V.D. aluminum coating per MIL-DTL-83488, Type II, Class 3, and cetyl lube per Hi-Shear Spec. 305.
- HST515CE(-)(-) = I.V.D. aluminum coating per MIL-DTL-83488, Type II, (.00015-.00045 thick), with color black on thread end, & cetyl alcohol lube per Hi-Shear Spec. 305.
- HST515CF(-)(-) = I.V.D. aluminum coating per MIL-DTL-83488, Type II, (.00015-.00045 thick), with color black on thread end.
- HST515CZ(-)(-) = Cetyl alcohol lube per Hi-Shear Spec. 305, with color black on thread end.
- HST515KV(-)(-) = Sulphuric acid anodizing per ISO8080 and Hi-Kote 1 aluminum pigmented coating per Hi-Shear Spec. 294 on threads only, and cetyl alcohol lube per Hi-Shear Spec. 305.
- HST515RP(-)(-) = Phosphate fluoride treat with color orange on thread end, and cetyl alcohol lube per Hi-Shear Spec. 305.
- HST515SY(-)(-) = Phosphate fluoride treat and solid film lube per AS5272, Type I.
- HST515TA(-)(-) = Ti-Shield III, Hi-Kote 2 solid film lube per Hi-Shear Spec. 292, and cetyl alcohol lube per Hi-Shear Spec. 305.
- HST515TB(-)(-) = Hi-Kote 2 solid film lube per Hi-Shear Spec. 292, and cetyl alcohol lube per Hi-Shear Spec. 305.
- HST515UT(-)(-) = Ti-Shield III, Hi-Kote 2 solid film lube per Hi-Shear Spec. 292.
- HST515UV(-)(-) = Surface coating per Hi-Shear Spec. 306, Type II, Hi-Kote 2 solid film lube per Hi-Shear Spec. 292, and cetyl alcohol lube per Hi-Shear Spec. 305.

- HST515KM(-)(-) = Hi-Kote 1 aluminum coating per Hi-Shear Spec. 294, with color white on thread end, and cetyl alcohol lube per Hi-Shear Spec. 305.
- HST515WF(-)(-) = Surface coating per Hi-Shear Spec. 306, Type I, color blue, with color black on thread end, and cetyl alcohol lube per Hi-Shear Spec. 305.
- HST515YV(-)(-) = Hi-Kote 2 solid film lube per Hi-Shear Spec. 292 on threads only, with color orange on thread end, and cetyl alcohol lube per Hi-Shear Spec. 305.
- HST515GD(-)(-) = Hi-Kote 1 aluminum pigmented coating on threads only per Hi-Shear Spec. 294, and cetyl alcohol lube per Hi-Shear Spec. 305.
- HST515GM(-)(-) = Hi-Kote 1 aluminum pigmented coating per Hi-Shear Spec. 294 on threads (no overspray on the shank is allowed) and top of head only (.005 max overspray on the head bearing surface permissible) with color white on thread end, and cetyl alcohol lube per Hi-Shear Spec. 305.

THIS AREA OF SPECIAL CONFIGURATION AND COLD WORKING TO MEET PHYSICAL REQUIREMENTS



**VIEW A**  
HI-LITE THREAD TRANSITION AREA  
SEE SPECIFICATION FOR INSPECTION

**SPECIFICATION:**

Hi-Lite Product Specification 380.

**CODE:**

First dash number indicates nominal diameter in 1/32nds of the pin which this HST515 oversize pin replaces. Second dash number indicates maximum grip in 1/16ths. See Finish note for explanation of code letters.

**HOW TO ORDER EXAMPLES:**

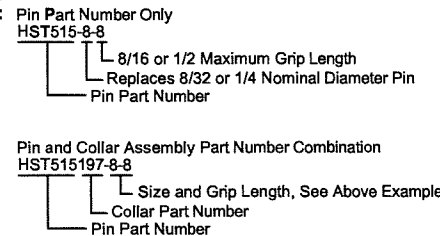

U.S. Patents 4,326,825; 4,485,510 and 4,957,401. Other U.S. and international patents pending. "Hi-Lite" and "HST" are registered trademarks and "Hi-Lite ST" is a trademark of Hi-Shear Corporation.		TITLE <b>HI-LITE® ST™ PIN</b>
DRAWN D.P.S.	DATE 8-1-86	130° FLUSH CROWN SHEAR HEAD TITANIUM 1/16" GRIP VARIATION, 1/32" OVERSIZE
APPROVED E.E. Beales	DATE 9-9-86	DRAWING NUMBER <b>HST515</b>
REVISION ⑦	DATE J.F. Obispo 7-9-2010	