

RESTRICTED USAGE FOR REPAIR WORK ONLY
 .0156 AND .0312 OVERSIZE SHANK FOR REPLACEMENT OF BOLTS SHOWN ON SHEET 1

MARK HEAD "HT4026", FIRST AND SECOND DASH NUMBERS, OVERSIZE DESIGNATION AS APPLICABLE (LETTER "X" OR "Y") AND MANUFACTURER'S IDENTIFICATION DEPRESSED .010 MAX (LOCATION OPTIONAL).

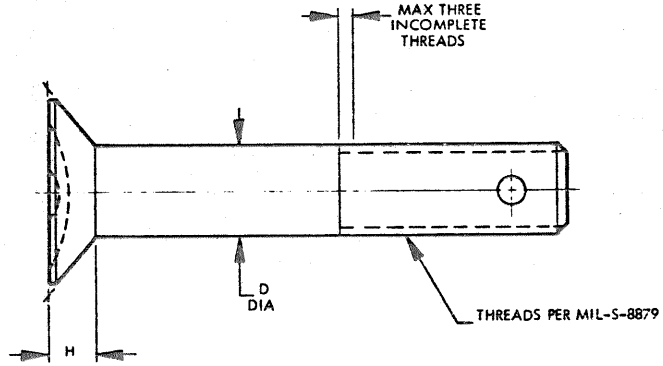
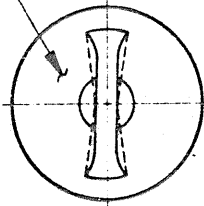

.0156 OVERSIZE Δ

PART NUMBER	D DIA		H REF
	Unplated	Plated	
HT4026-3() (X)	.2026 .2021	.2026 .2016	.073
HT4026-4() (X)	.2651 .2646	.2651 .2641	.099
HT4026-5() (X)	.3276 .3271	.3276 .3266	.126
HT4026-6() (X)	.3901 .3896	.3901 .3891	.153
HT4026-7() (X)	.4526 .4521	.4526 .4516	.181
HT4026-8() (X)	.5151 .5146	.5151 .5141	.208
HT4026-9() (X)	.5771 .5766	.5771 .5761	.235
HT4026-10() (X)	.6396 .6391	.6396 .6386	.268

.0312 OVERSIZE Δ

PART NUMBER	D DIA		H REF
	Unplated	Plated	
HT4026-3() (Y)	.2182 .2177	.2182 .2172	.067
HT4026-4() (Y)	.2807 .2802	.2807 .2792	.095
HT4026-5() (Y)	.3432 .3427	.3432 .3422	.120
HT4026-6() (Y)	.4057 .4052	.4057 .4047	.147
HT4026-7() (Y)	.4682 .4677	.4682 .4672	.175
HT4026-8() (Y)	.5307 .5302	.5307 .5297	.202
HT4026-9() (Y)	.5927 .5922	.5927 .5917	.229
HT4026-10() (Y)	.6552 .6547	.6552 .6542	.257

Δ FOR MATERIAL, FINISH, PROCUREMENT INFORMATION AND DIMENSIONS NOT SHOWN SEE SHEET 1.

U.S. PATENT NUMBERS: 2,745,120; 2,808,087; 2,864,418; 2,949,949; 2,954,719; 2,994,354; 3,060,565; 3,103,675; 3,388,411; OTHER U.S. AND FOREIGN PATENTS PENDING

DRAWN
 18 DECEMBER 1972
 REV. LETTER AND DATE
 (B) 12 OCTOBER 1973

HI-TORQUE[®]
 BOLT, 100°
 CLOSE TOLERANCE, LONG THREAD
 160 KSI MIN SHEAR

DRAWING NUMBER
 HT 4026
 SHEET 2 OF 2